



02.13 IN INOX CASE FOR FRONT PANEL MOUNTING WITH U-CLAMP

LEITENBERGER

Mess- und Regeltechnik GmbH

Bahnhofstraße 32/33

D-72138 Kirchentellinsfurt

Fon: +49 (0)7121/908-0

Fax: +49 (0)7121/908-200

E-Mail: mrt-info@leitenberger.de

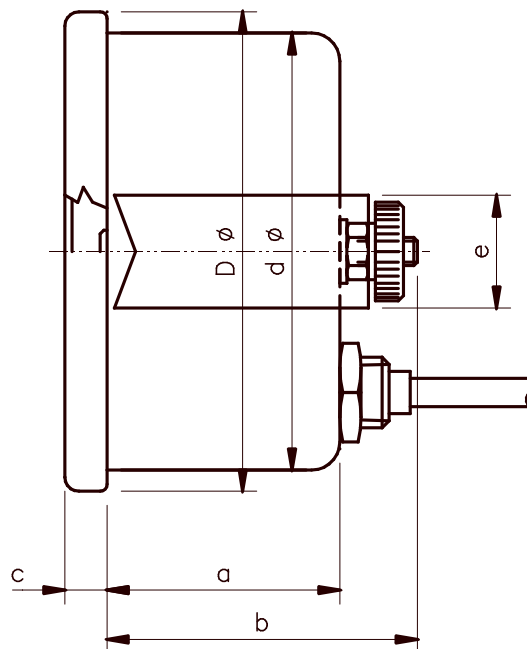

Type	a	b	c	d	D	l
1063 KB/V	1.3	1.89	0.24	2.48	2.68	0.14
1080 KB/V	1.18	1.77	0.24	3.15	3.35	0.14
1100 KB/V	1.18	1.77	0.28	3.94	4.13	0.18
1160 KB/V	1.38	1.97	0.51	6.3	7.48	7.01

Unit: Inch

Case: stainless steel
 Mounting: panel mounting with u-clamp
 Window: Ø 63 and Ø 80 glass, clear, Ø 100 Makrolon resistant up to 65 °C or 149 °F
 U-clamp: steel sheet corrosion protected
 Measuring system: double bourdon spring system, with bimetal compensation
 Scale: white - black prints
 Scale length: approx. 270 [°]
 Graduation: 1°, 2°, 5°, 10° depending on range
 Range: between -80 ... +380 °C
 -112 ... +716 °F
 Accuracy: class 2 acc. DIN 16203
 Pointer: black
 Capillary connection: back

Options:

- customized dial
- coloured scale
- back adjustment
- accuracy ±1 %, ±1,5 %
- glycerine filling
- bottom connection